



STAIRVILLE

RevueLED 120 COB
RGBW DMX
LED spotlight

Musikhaus Thomann
Thomann GmbH
Hans-Thomann-Straße 1
96138 Burgebrach
Germany
Telephone: +49 (0) 9546 9223-0
E-mail: info@thomann.de
Internet: www.thomann.de

27.10.2017, ID: 414200

Table of contents

1	General notes	5
	1.1 Further information.....	6
	1.2 Notational conventions.....	7
	1.3 Symbols and signal words.....	8
2	Safety instructions	11
3	Features	16
4	Installation	17
5	Starting up	21
6	Connections and controls	24
7	Operating	27
	7.1 Menu overview.....	31
	7.2 Functions in DMX mode.....	32
8	Technical specifications	33
9	Plug and connection assignments	35

10	Troubleshooting.....	36
11	Cleaning.....	38
12	Protecting the environment.....	39

1 General notes

This manual contains important instructions for the safe operation of the unit. Read and follow the safety instructions and all other instructions. Keep the manual for future reference. Make sure that it is available to all those using the device. If you sell the unit please make sure that the buyer also receives this manual.

Our products are subject to a process of continuous development. Thus, they are subject to change.

1.1 Further information

On our website (www.thomann.de) you will find lots of further information and details on the following points:

Download	This manual is also available as PDF file for you to download.
Keyword search	Use the search function in the electronic version to find the topics of interest for you quickly.
Online guides	Our online guides provide detailed information on technical basics and terms.
Personal consultation	For personal consultation please contact our technical hotline.
Service	If you have any problems with the device the customer service will gladly assist you.

1.2 Notational conventions

This manual uses the following notational conventions:

Letterings

The letterings for connectors and controls are marked by square brackets and italics.

Examples: *[VOLUME]* control, *[Mono]* button.

Displays

Texts and values displayed on the device are marked by quotation marks and italics.

Examples: *'24ch'*, *'OFF'*.

Instructions



The individual steps of an instruction are numbered consecutively. The result of a step is indented and highlighted by an arrow.

Example:

- 1.** ▶ Switch on the device.
- 2.** ▶ Press *[Auto]*.
 - ⇒ Automatic operation is started.
- 3.** ▶ Switch off the device.

1.3 Symbols and signal words

In this section you will find an overview of the meaning of symbols and signal words that are used in this manual.

Signal word	Meaning
DANGER!	This combination of symbol and signal word indicates an immediate dangerous situation that will result in death or serious injury if it is not avoided.
WARNING!	This combination of symbol and signal word indicates a possible dangerous situation that can result in death or serious injury if it is not avoided.
NOTICE!	This combination of symbol and signal word indicates a possible dangerous situation that can result in material and environmental damage if it is not avoided.
Warning signs	Type of danger
	Warning – high-voltage.
	Warning – suspended load.

Warning signs	Type of danger
	Warning – danger zone.

2 Safety instructions

Intended use

This device is intended to be used as an electronic illumination effect using LED technics. The device is designed for professional use and is not suitable for use in households. Use the device only as described in this user manual. Any other use or use under other operating conditions is considered to be improper and may result in personal injury or property damage. No liability will be assumed for damages resulting from improper use.

This device may be used only by persons with sufficient physical, sensorial, and intellectual abilities and having corresponding knowledge and experience. Other persons may use this device only if they are supervised or instructed by a person who is responsible for their safety.

Safety



DANGER!

Danger for children

Ensure that plastic bags, packaging, etc. are disposed of properly and are not within reach of babies and young children. Choking hazard!

Ensure that children do not detach any small parts (e.g. knobs or the like) from the unit. They could swallow the pieces and choke!

Never let children unattended use electrical devices.



DANGER!

Electric shock caused by high voltages inside

Within the device there are areas where high voltages may be present. Never remove any covers.

There are no user-serviceable parts inside.

Do not use the device if covers, protectors or optical components are missing or damaged.



DANGER!

Electric shock caused by short-circuit

Always use proper ready-made insulated mains cabling (power cord) with a protective contact plug. Do not modify the mains cable or the plug. Failure to do so could result in electric shock/death or fire. If in doubt, seek advice from a registered electrician.



WARNING!

Eye damage caused by high light intensity

Never look directly into the light source.



WARNING!

Risk of epileptic shock

Strobe lighting can trigger seizures in photosensitive epilepsy. Sensitive persons should avoid looking at strobe lights.



NOTICE!

Risk of fire

Do not block areas of ventilation. Do not install the device near any direct heat source. Keep the device away from naked flames.



NOTICE!

Operating conditions

This device has been designed for indoor use only. To prevent damage, never expose the device to any liquid or moisture. Avoid direct sunlight, heavy dirt, and strong vibrations.



NOTICE!

Power supply

Before connecting the device, ensure that the input voltage (AC outlet) matches the voltage rating of the device and that the AC outlet is protected by a residual current circuit breaker. Failure to do so could result in damage to the device and possibly injure the user.

Unplug the device before electrical storms occur and when it is unused for long periods of time to reduce the risk of electric shock or fire.

3 Features

LED spotlight for very large-area and uniform lighting in showrooms or workshops, trade show booths, etc.

- LED configuration: 1 × COB RGBW LED
- Beam angle: 50°
- Replacement for 575 W daylight lamps
- Control via DMX and via buttons and display on the unit
- Power Twist connectors for self-supply and for supplying further devices
- sturdy double bracket for secure attachment to trusses or firm footing on the ground

4 Installation

Unpack and carefully check that there is no transportation damage before using the unit. Keep the equipment packaging. To fully protect the device against vibration, dust and moisture during transportation or storage use the original packaging or your own packaging material suitable for transport or storage, respectively.



WARNING!

Risk of injury caused by falling objects

Make sure that the installation complies with the standards and rules that apply in your country. Always secure the device with a secondary safety attachment, such as a safety cable or a safety chain.



NOTICE!

Risk of overheating

Always ensure sufficient ventilation.

The ambient temperature must always be below 40 °C (104 °F).



NOTICE!

Use of stands

When mounting the device onto a stand, ensure that the stand is in a safe and stable position and that the weight of the device does not exceed the maximum permissible load capacity of the stand.

**NOTICE!****Possible data transmission errors**

For error-free operation make use of dedicated DMX cables and do not use ordinary microphone cables.

Never connect the DMX input or output to audio devices such as mixers or amplifiers.

Mounting options

You can install the unit in hanging or standing position. When in use, the device must always be attached to a solid surface or an approved truss. Use the openings provided on the two-piece bracket for attaching.

Always work from a stable platform whenever installing, moving or servicing the unit. In doing so, the area underneath the unit must be cordoned off.

The safety cable must be threaded through this safety eyelet.



Please note that this device must not be connected to a dimmer.

5 Starting up

Create all connections while the device is off. Use the shortest possible high-quality cables for all connections. Take care when running the cables to prevent tripping hazards.

Connections in DMX mode

Connect the DMX input of the device to the DMX output of a DMX controller or another DMX device. Connect the output of the first DMX device to the input of the second one, and so on to form a daisy chain. Always ensure that the output of the last DMX device in the daisy chain is terminated with a resistor ($110\ \Omega$, $\frac{1}{4}\text{ W}$).

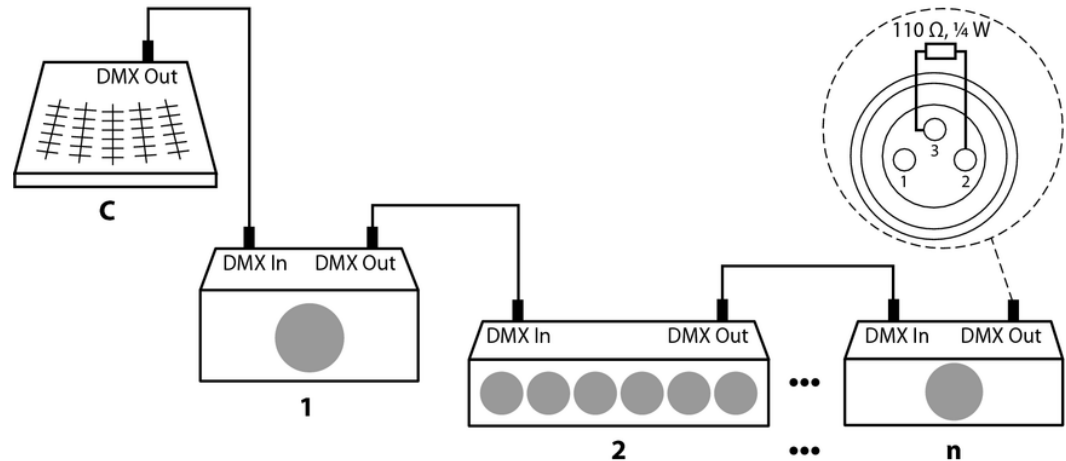

Connections in master/slave mode

When you configure a group of devices in master/slave mode, the first unit will control the other units for an automatic, sound-activated, synchronized show. This function is ideal when you want to start a show immediately. Connect the DMX output of the master device to the DMX input of the first slave device. Then connect the DMX output of the first slave device to the DMX input of the second slave device and so on.

6 Connections and controls

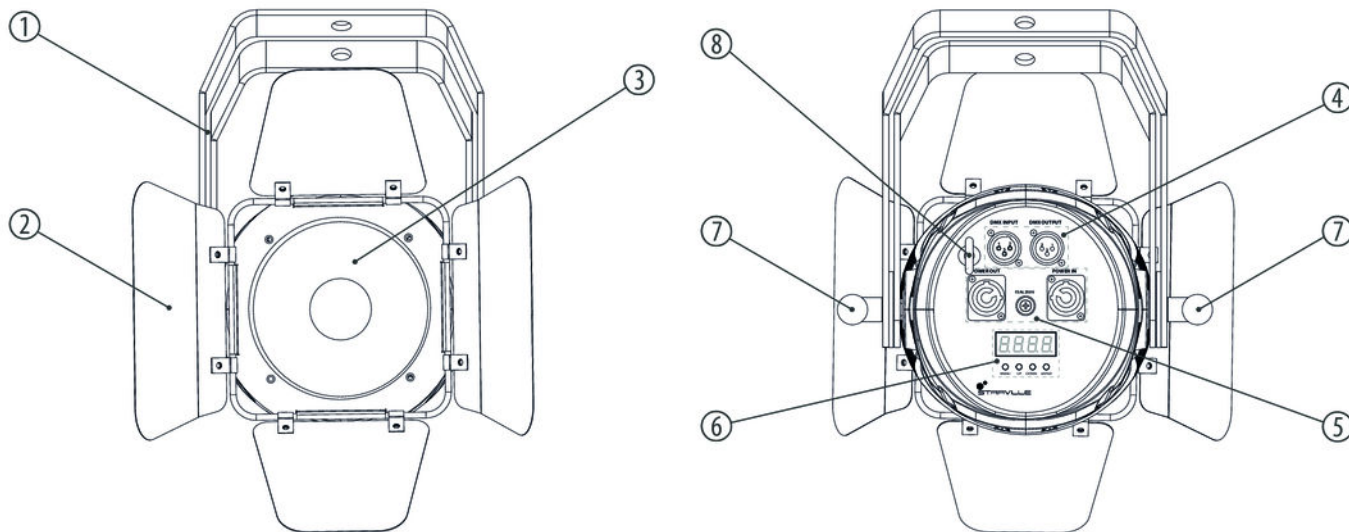

1	Two-piece bracket for hanging or installation and for securing the safety-rope.
2	Barn doors for directing the light beam.
3	LED
4	<i>[DMX IN]</i> : DMX input socket <i>[DMX OUT]</i> : DMX output socket
5	<i>[Power In]</i> : Power-Twist connector for the power supply of the device. <i>[Power Out]</i> : Power-Twist connector for the voltage supply of a connected device. Fuse holder
6	Display and control buttons: <i>[Menu]</i> : Activates the main menu and toggles between menu items. <i>[Up]</i> : Increases the displayed value by one. <i>[Down]</i> : Decreases the displayed value by one. <i>[Enter]</i> : Selects an option of the respective operating mode.

7	Locking screw for fixing the spotlight.
---	---

8	Safety cable eyelet
---	---------------------

7 Operating

Connect the device to the power supply to start operation.

Operating mode DMX

This setting is only relevant if the device is controlled via a DMX controller.

1. ➤ Use *[UP]* or *[DOWN]* to select the menu option 'DMX' and confirm with *[ENTER]*.
2. ➤ Use *[UP]* and *[DOWN]* to assign a DMX address in the range from 'A001' ... 'A506' to the device (highest possible DMX address in 7-channel operation) and confirm with *[ENTER]*.

Operating mode Slave

In this mode, the device exactly follows the operation of the master that it is connected to.

1. ➤ Use *[UP]* or *[DOWN]* to select the menu option 'Slave' and confirm with *[ENTER]*.
2. ➤ Use *[UP]* and *[DOWN]* to enable the desired Slave mode ('SLO' ... 'SL3') and confirm with *[ENTER]*.

Operating mode Auto

In this mode, the device projects programmed patterns automatically onto a surface.

1. ➤ Use *[UP]* or *[DOWN]* to select the menu option 'Auto' and confirm with *[ENTER]*.
2. ➤ Use *[UP]* and *[DOWN]* to specify the speed of the automatic programme ('AU00' ... 'AU99') and confirm with *[ENTER]*.

Sound control

In this mode, the device projects programmed patterns sound-controlled onto a surface.

1. ➤ Use *[UP]* or *[DOWN]* to select the menu option 'Sound' and confirm with *[ENTER]*.
2. ➤ Use *[UP]* and *[DOWN]* to enable the desired Sound mode ('SD00' ... 'SD99') and confirm with *[ENTER]*.

Colour mixture

In this menu, you have the option to specify a certain colour mixture based on the four basic colours red, green, blue and white.

1. ➤ Use *[UP]* or *[DOWN]* to select the menu option 'Mixing Color' and confirm with *[ENTER]*.
2. ➤ Use *[UP]* and *[DOWN]* to specify the speed ('FA00' ... 'FA99') and confirm with *[ENTER]*.

Fixed colour

In this menu, you have the option to specify a certain fixed colour.

1. ➤ Use *[UP]* or *[DOWN]* to select the menu option 'Color Set' and confirm with *[ENTER]*.
2. ➤ Use *[UP]* and *[DOWN]* to enable the desired Sound mode ('F100' ... 'F114') and confirm with *[ENTER]*.

Stroboscope

In this menu, you have the option to set the strobe frequency. This setting is only relevant if the device is not controlled via a DMX controller.

1. ➤ Use *[UP]* or *[DOWN]* to select the menu option 'Strobe' and confirm with *[Enter]*.
2. ➤ Use *[UP]* and *[DOWN]* to specify the flash frequency for the Strobe effect in a range from 'ST00' ... 'ST99' (fast ... slow) and confirm with *[ENTER]*.

Preset dimmer red

In this menu, you have the option to adjust the dimmer settings for the colour red. This setting is only relevant if the device is not controlled via a DMX controller.

1. ➤ Use *[UP]* or *[DOWN]* to select the menu option 'Red Dimmer' and confirm with *[ENTER]*.
2. ➤ Use *[UP]* and *[DOWN]* to specify the intensity of the colour red in a range from 'r000' ... 'r255' (off, dark ... bright) and confirm with *[ENTER]*.

Preset dimmer green

In this menu, you have the option to adjust the dimmer settings for the colour green. This setting is only relevant if the device is not controlled via a DMX controller.

1. ➤ Use *[UP]* or *[DOWN]* to select the menu option 'Green Dimmer' and confirm with *[ENTER]*.
2. ➤ Use *[UP]* and *[DOWN]* to specify the intensity of the colour green in a range from 'g000' ... 'g255' (off, dark ... bright) and confirm with *[ENTER]*.

Preset dimmer blue

In this menu, you have the option to adjust the dimmer settings for the colour blue. This setting is only relevant if the device is not controlled via a DMX controller.

1. ➤ Use *[UP]* or *[DOWN]* to select the menu option 'Blue Dimmer' and confirm with *[ENTER]*.
2. ➤ Use *[UP]* and *[DOWN]* to specify the intensity of the colour blue in a range from 'b000' ... 'b255' (off, dark ... bright) and confirm with *[ENTER]*.

Preset dimmer white

In this menu, you have the option to adjust the dimmer settings for the colour white. This setting is only relevant if the device is not controlled via a DMX controller.

1. ➤ Use *[UP]* or *[DOWN]* to select the menu option 'White Dimmer' and confirm with *[ENTER]*.
2. ➤ Use *[UP]* and *[DOWN]* to specify the intensity of the colour white in a range from 'u000' ... 'u255' (off, dark ... bright) and confirm with *[ENTER]*.

7.1 Menu overview

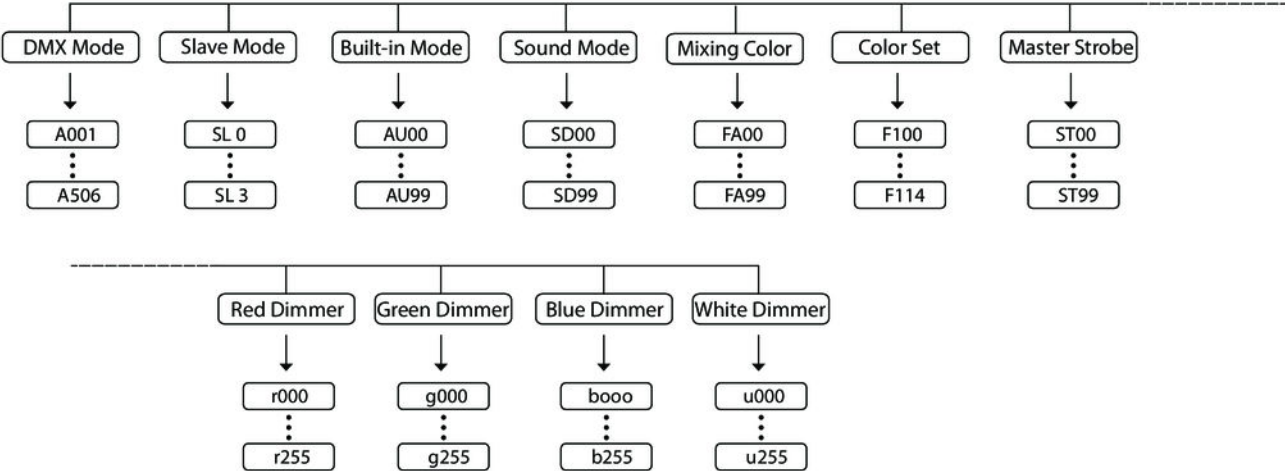

7.2 Functions in DMX mode

Channel	Value	Function
1	0 ... 255	Intensity red (0 % to 100 %)
2	0 ... 255	Intensity green (0 % to 100 %)
3	0 ... 255	Intensity blue (0 % to 100 %)
4	0 ... 255	Intensity white (0 % to 100 %)
5	0 ... 255	Master dimmer (0 % to 100 %)
6	0 ... 255	Strobe effect (0 % to 100 %)
7	0 ... 255	Built-in automatic show programmes

8 Technical specifications

LED configuration:	1 × COB LED RGBW, 120 W
Number of DMX channels:	7
Beam angle	50 °
Refresh rate	8000 Hz
DMX input, DMX output	XLR 3-pin
Power consumption	130 W
Operating supply voltage	AC 100 – 240 V ~ 50/60 Hz
Fuse	5 mm × 20 mm, 2 A, 250 V, slow-blow
Dimensions (W × H × D)	258 mm × 164 mm × 557 mm
Weight	5.5 kg

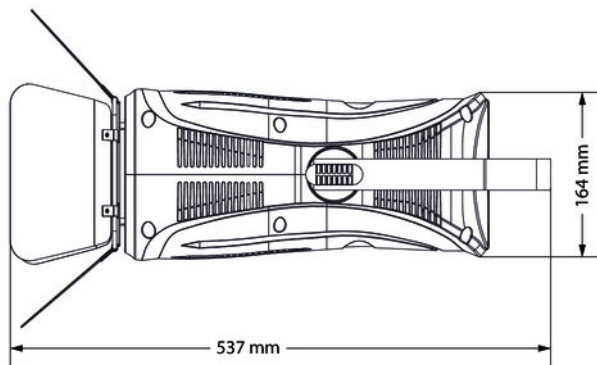
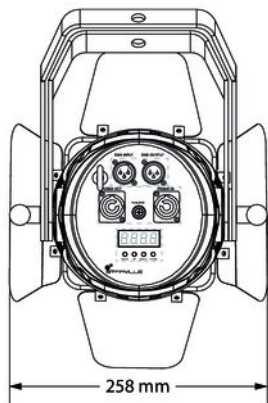

9 Plug and connection assignments

Introduction

This chapter will help you select the right cables and plugs to connect your valuable equipment so that a perfect light experience is guaranteed.

Please take our tips, because especially in 'Sound & Light' caution is indicated: Even if a plug fits into a socket, the result of an incorrect connection may be a destroyed DMX controller, a short circuit or 'just' a not working light show!

DMX connections



The unit offers a 3-pin XLR socket for DMX output and a 3-pin XLR plug for DMX input. Please refer to the drawing and table below for the pin assignment of a suitable XLR plug.

Pin	Configuration
1	Ground, shielding
2	Signal inverted (DMX-, 'cold signal')
3	Signal (DMX+, 'hot signal')

10 Troubleshooting



NOTICE!

Possible data transmission errors

For error-free operation make use of dedicated DMX cables and do not use ordinary microphone cables.

Never connect the DMX input or output to audio devices such as mixers or amplifiers.

In the following we list a few common problems that may occur during operation. We give you some suggestions for easy troubleshooting:

Symptom	Remedy
The unit does not work, no light.	Check the mains connection and the fuse.
No response to the DMX controller.	1. Check the DMX ports and cables for proper connection.
	2. Check the address settings and the DMX polarity.
	3. Try using another DMX controller.
	4. Check to see if the DMX cables run near or alongside to high voltage cables that may cause damage or interference to DMX interface circuits.

If the procedures recommended above do not succeed, please contact our Service Center. You can find the contact information at www.thomann.de.

11 Cleaning

Optical lenses

Clean the optical lenses, that are accessible from the outside, regularly in order to optimize the light output. The frequency of cleaning depends on the operating environment: wet, smoky or particularly dirty surroundings can cause more accumulation of dirt on the optics of the device.

- Clean with a soft cloth using our lamp and lens cleaner (item no. 280122).
- Always dry the parts carefully.

12 Protecting the environment

Disposal of the packaging material



For the transport and protective packaging, environmentally friendly materials have been chosen that can be supplied to normal recycling.

Ensure that plastic bags, packaging, etc. are properly disposed of.

Do not just dispose of these materials with your normal household waste, but make sure that they are collected for recycling. Please follow the notes and markings on the packaging.

Disposal of your old device



This product is subject to the European Waste Electrical and Electronic Equipment Directive (WEEE). Do not dispose with your normal household waste.

Dispose of this device through an approved waste disposal firm or through your local waste facility. When discarding the device, comply with the rules and regulations that apply in your country. If in doubt, consult your local waste disposal facility.

RevueLED 120 COB RGBW DMX



Musikhaus Thomann · Hans-Thomann-Straße 1 · 96138 Burgebrach · Germany · www.thomann.de